



*ONOS based multi-domain  
slicing over white-box switches*

*Jaime Azcorra*



- Introduction
  - Software-Defined Networks and Network Function Virtualization
  - Network Slices
- Network Slicing in SDN Deployments
- 5G Networks
- C3 in Fog Computing
- Conclusions

## SDN

Software Defined Networks facilitate the control of the network by viewing the network as a single entity. This approach centralizes the network intelligence by disassociating the process in charge of forwarding network packets (Data Plane) from the routing process (Control plane).

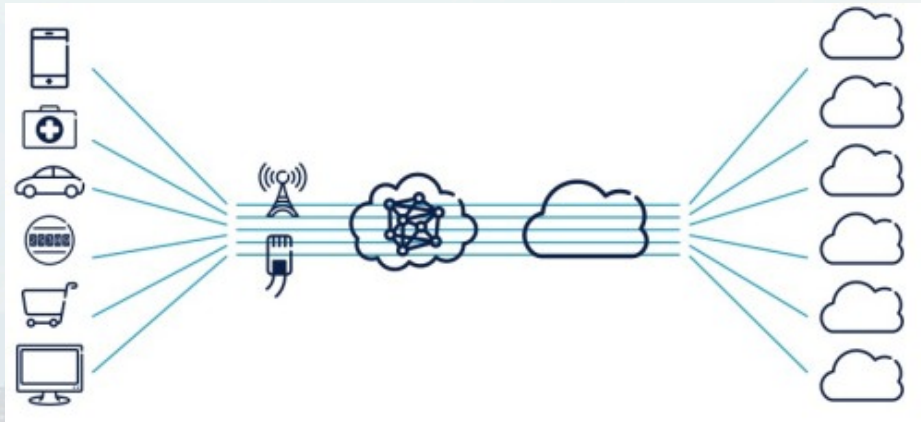
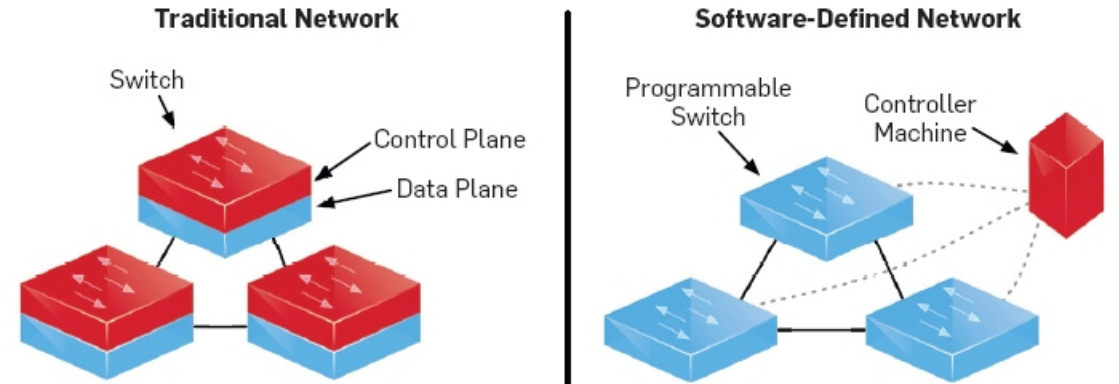

Source: .SDxCentral; What is Network Slicing?

## Network Slicing

Allows the creation of multiple virtual networks on top of a single shared physical infrastructure

Network slicing permits the creation of slices devoted to logical, self-contained, partitioned network functions



## Disadvantages of traditional solutions

- Topologically rigid
- Topologically static
- Capacity static
- Encapsulation inefficiency
- Security concerns
- Higher-layer blind



Consists of a distributed, vertical setup formed by a two-layer hierarchical system of controllers.

On the lower level, ONOS nodes have a local view of the network, administrating the bundle of branches composing a region associated to them.

On top of them, a single orchestrator (controller) manages these nodes and abstract the state changes forwarded by them in order to maintain a global and updated view of the whole Service domain.

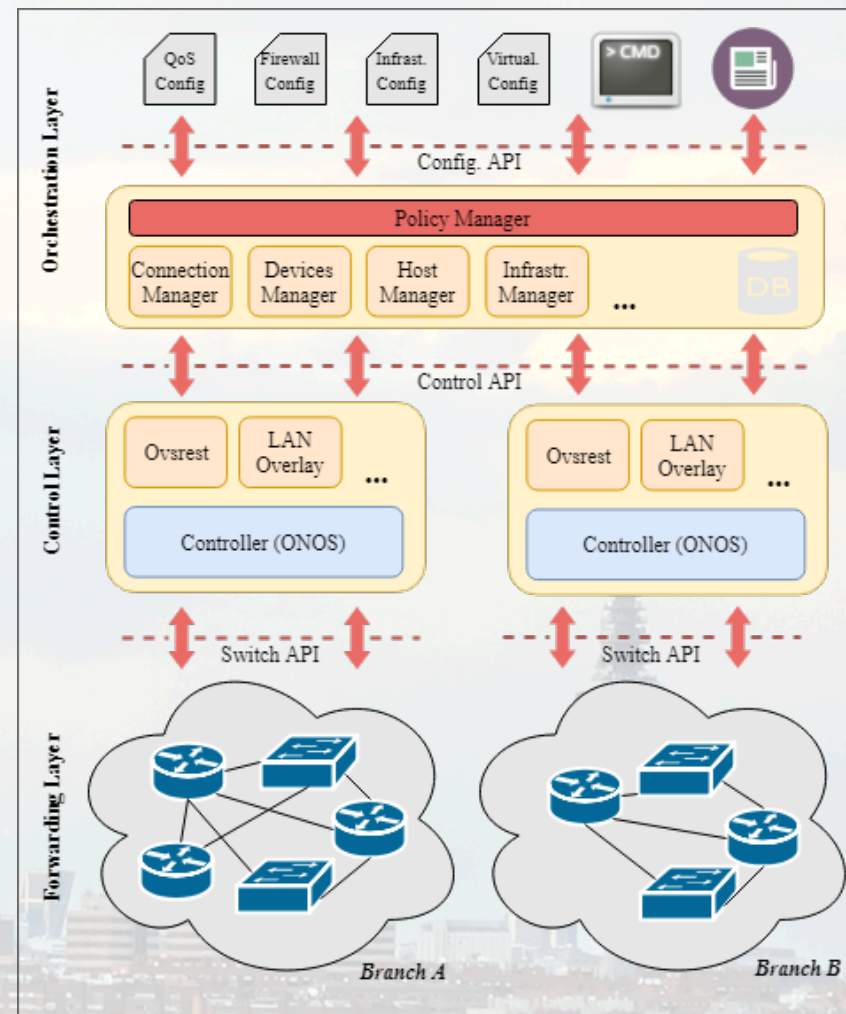

# Example of C3 topology

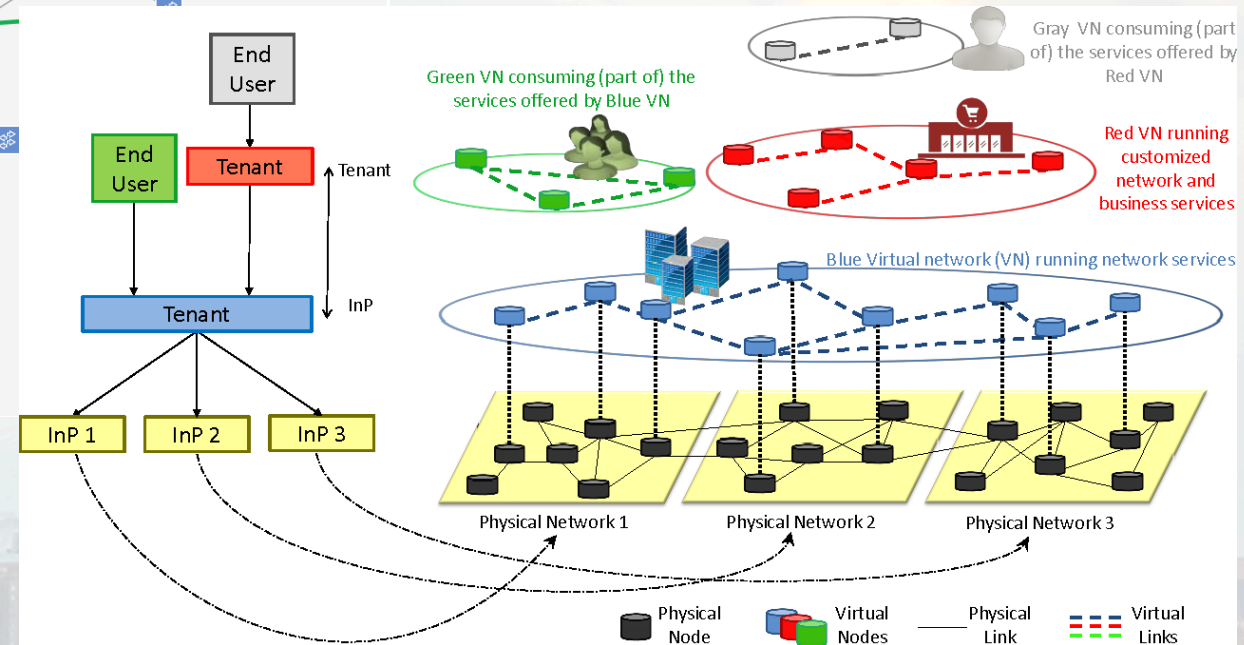
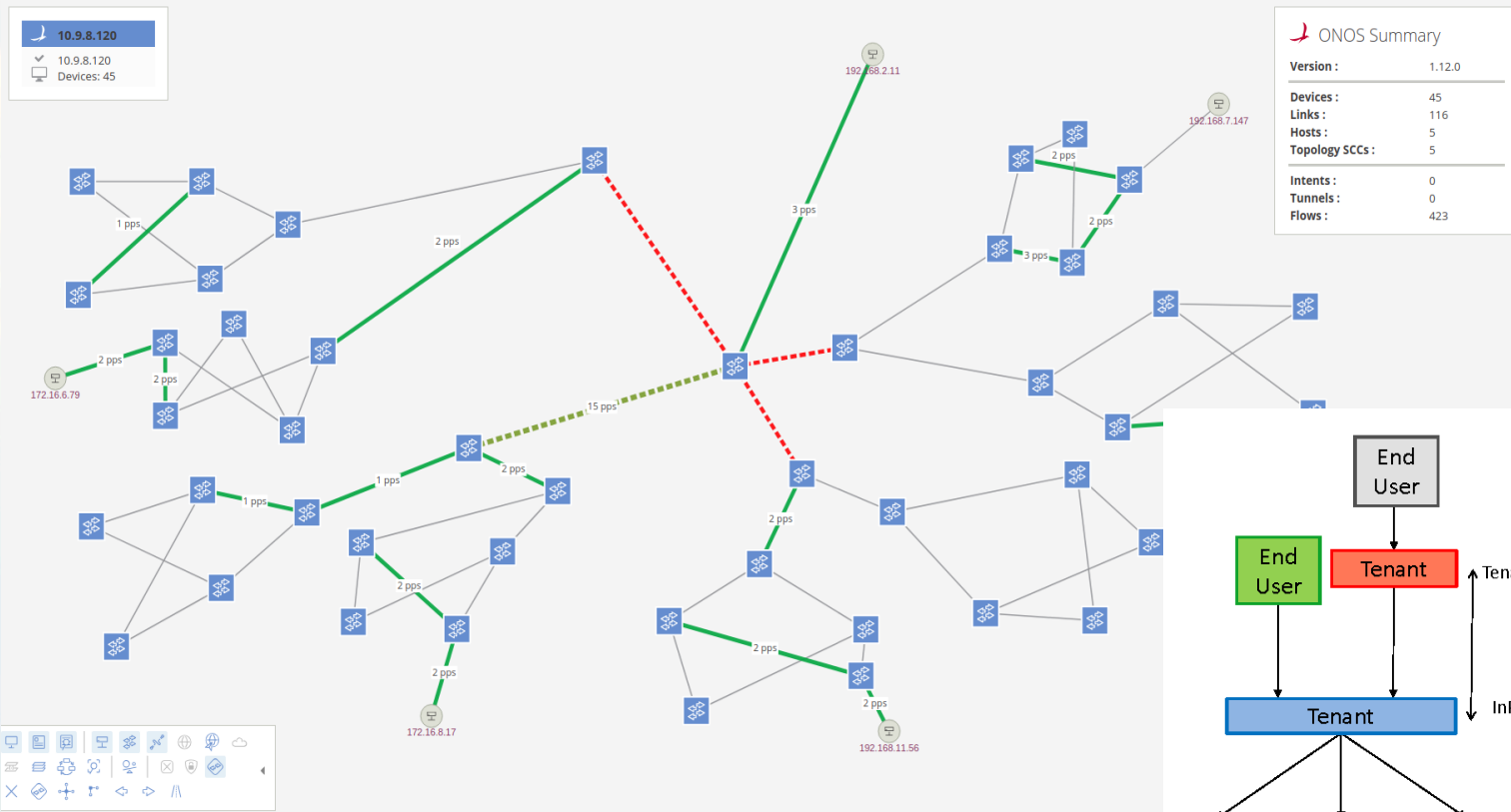

# 5G – much more than mobile broadband

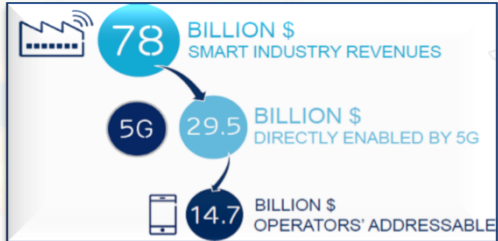

Source: Ericsson Arthur D. Little; Major strategic choices of TelCos: Reconfiguring for value

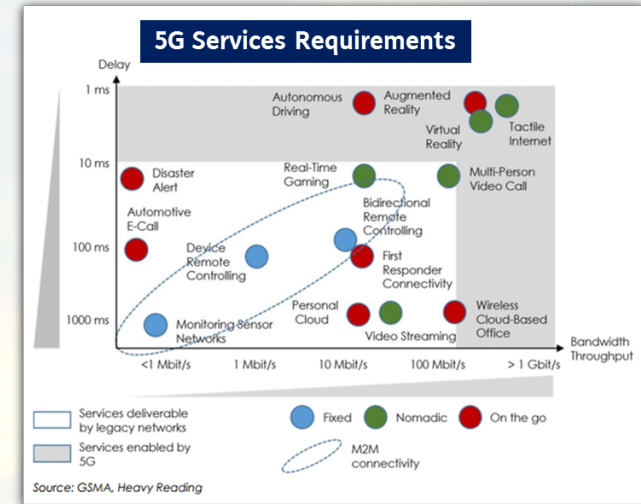
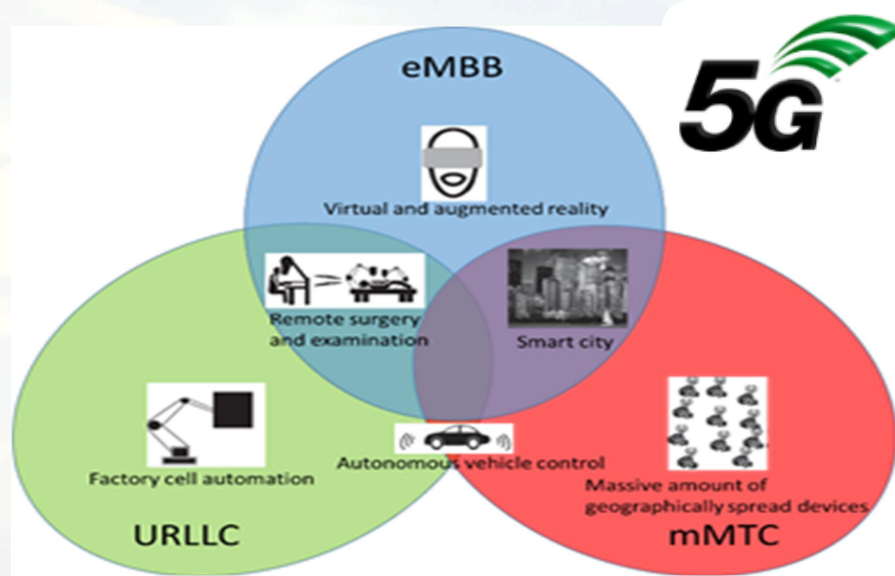
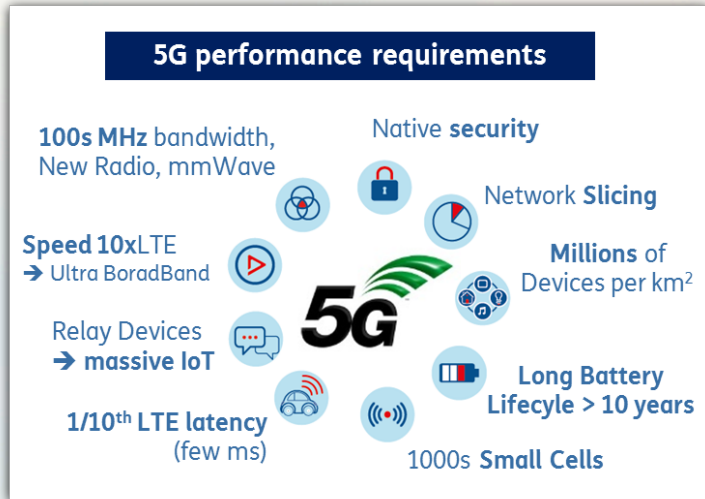

- Higher data rates, density, coverage and user mobility
- Improvements in latency, reliability & availability
- Use cases with massive number of devices
- Natively modular system deployed and scaled on-demand for a plethora of devices and services

- Highly Heterogeneous Network (**HetNet**) with multiple types of Radio Access Technologies (**RATs**), both fixed and wireless, in both licensed and unlicensed spectrum
- High performance parameters providing limitless types of applications and services



# Proposed Edge architecture

**Edge Server / Fog device** - can run a virtualized WAN branch function. Needs connectivity to internet/network, and network interfaces depending on the configuration set.

**Branch infrastructure** - virtual or real links that connect all elements involved in the C3 service.

**802.11 and LTE access points** - provide connectivity to the network and thus reach the EFS and OCS. Using context information, the system would balance between both technologies.

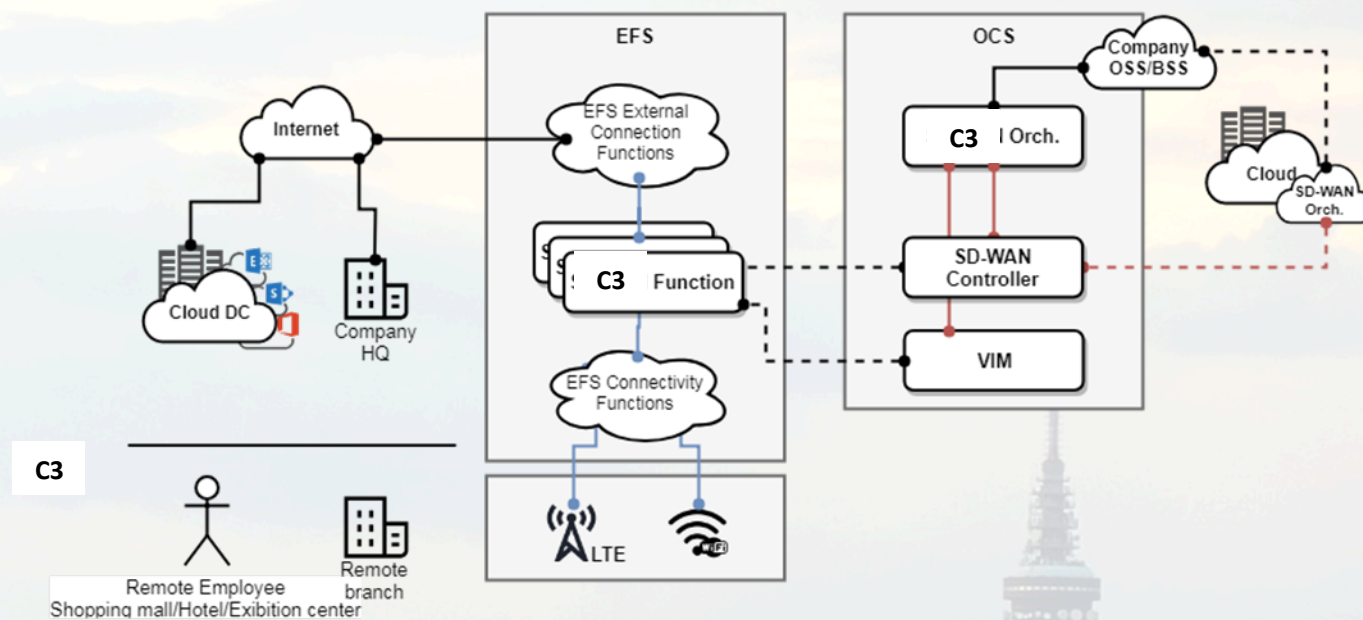

# EFS function management

- By leveraging 5G ecosystem, C3 orchestration will develop this network technology adding multi-RAT support, latency reduction, flexible network configuration and dynamic management based on network and resource monitoring.
- Regarding the mapping of the use case with 5G, C3 function and Virtual WiFi AP are the two entities deployed in the EFS. The C3 function deploys a WAN branch, under the management of the OCS components.

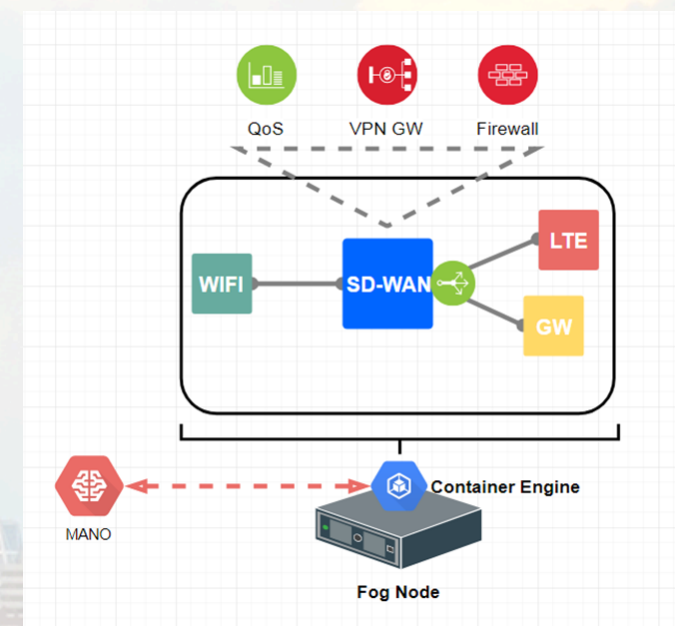
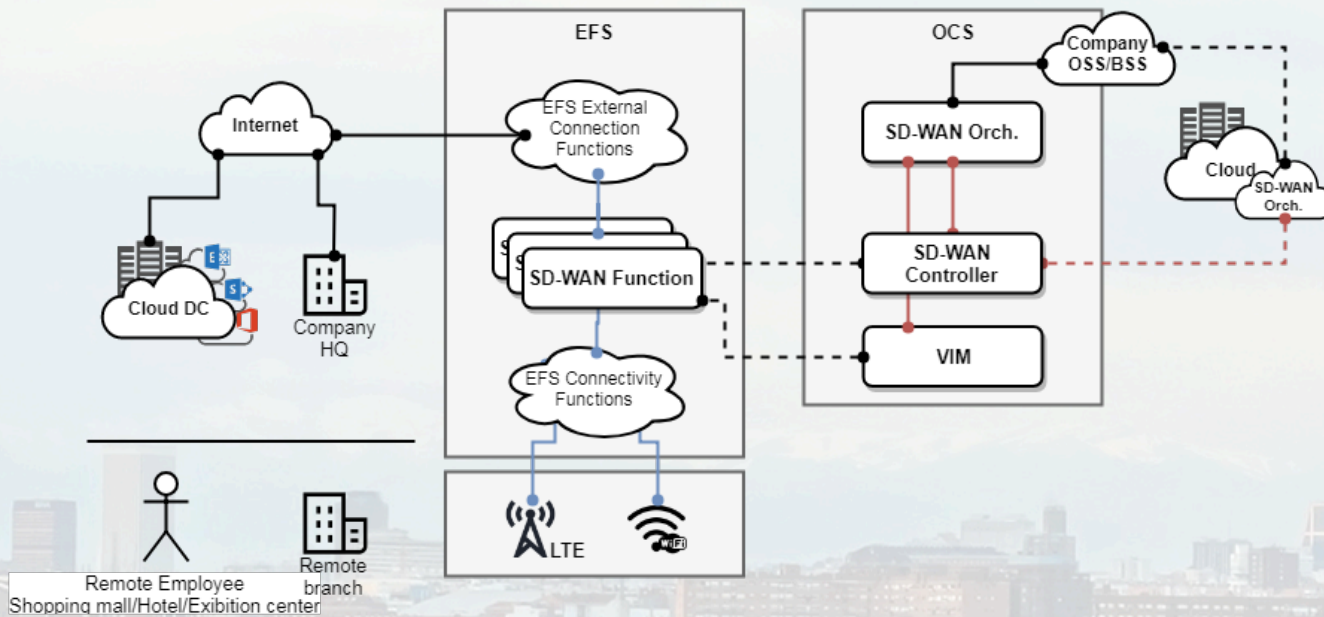

The use case pursues the following four objectives:

1. Develop EFS functions using multiple RATS and network offloading (C3 function).
2. Integration of EFS with central clouds (e.g. bank cloud), enabling the instantiation and migration of virtual functions.
3. Orchestration and control algorithms for dynamic EFS functions and resources (traffic balancing, scalability).
4. Integration and validation of EFS and OCS in large-scale testbeds

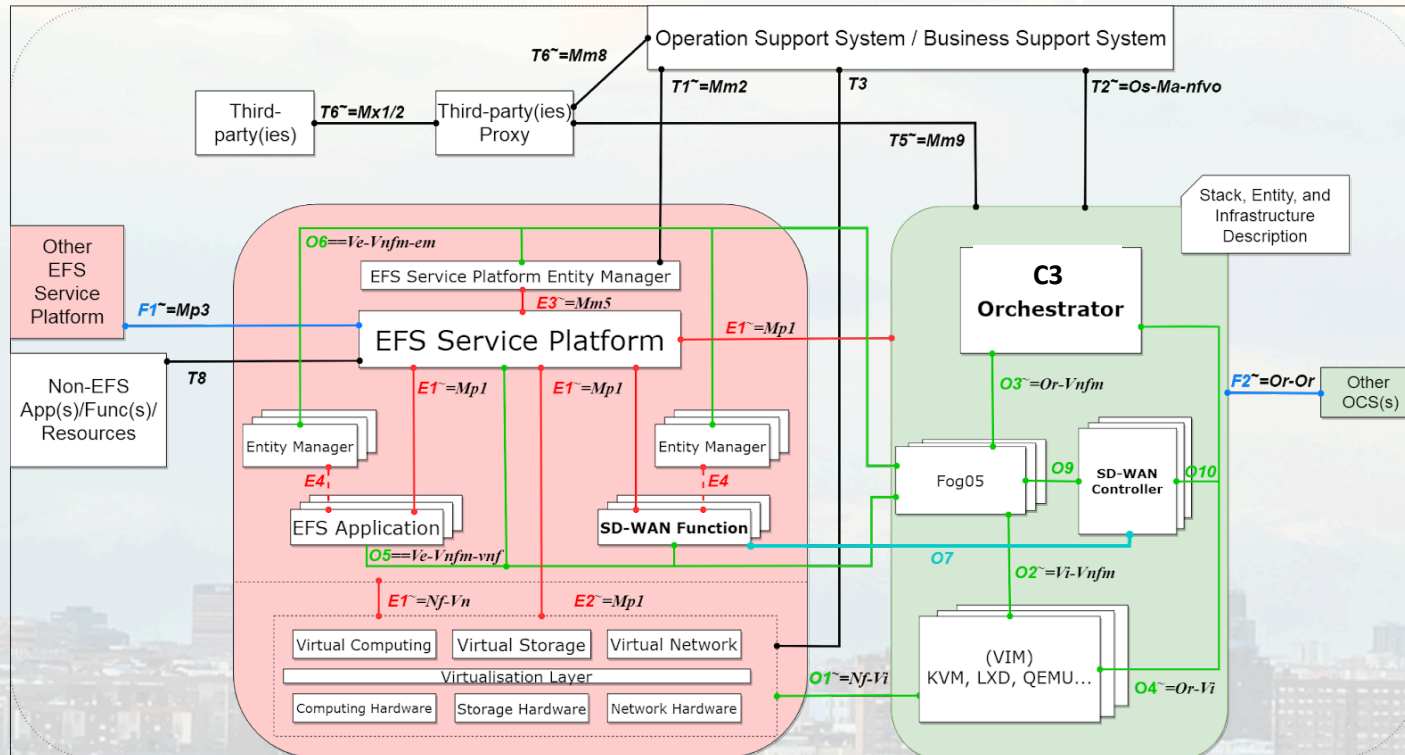





*Thanks for your attention!*

